

Step 7

RUBBER TRIM INSTALLATION

Before you install the step slider, you need to install the rubber trim on both sides.

Place the rubber trim at the endcap of your step. Press it to the inner edge of the step slider. The trim may stretch, cut if necessary to fit between both endcaps.



IMPORTANT

DO NOT SKIP THIS STEP.
The rubber trim protects the side of your vehicle.

Step 8

MECHANICAL INSTALLATION OF THE STEP SLIDERS

With the harness installed, tighten up your zip ties and secure the harness into place. Making sure there are no parts of the harness hanging below the body.

Remove these factory brackets on the middle and rear of the Bronco, along with these pinch seam bolts.

IMPORTANT

Keep your pinch seam bolts. You will re-use them to install the spacer plate.



Step 9

Starting on the driver side, locate the two body bolts on the underside of the vehicle. Loosen the two body bolts about 1/4" to allow free movement of the washer up and down. It should only move enough to slide your brackets into place. Repeat this step on the passenger side.

Breaker may be required to loosen body bolts.

TIP FROM A MECHANIC

As you start loosening, as soon as you hear the bolt pop or feel it bind, reverse direction 1/8 to 1/4 turn to clear the threads. This will make it easier as you progress. Even if you do not hear it pop do the reverse direction early on to prevent body bolt damage.

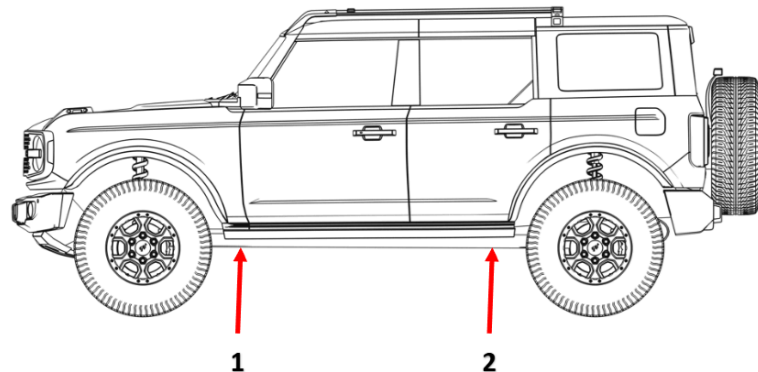

IMPORTANT

RSE is not responsible for any body bolt damage. Please visit your Ford dealership or regular mechanic for assistance.