

**Charging System - System Operation and Component Description**

**System Operation**

**System Diagram**

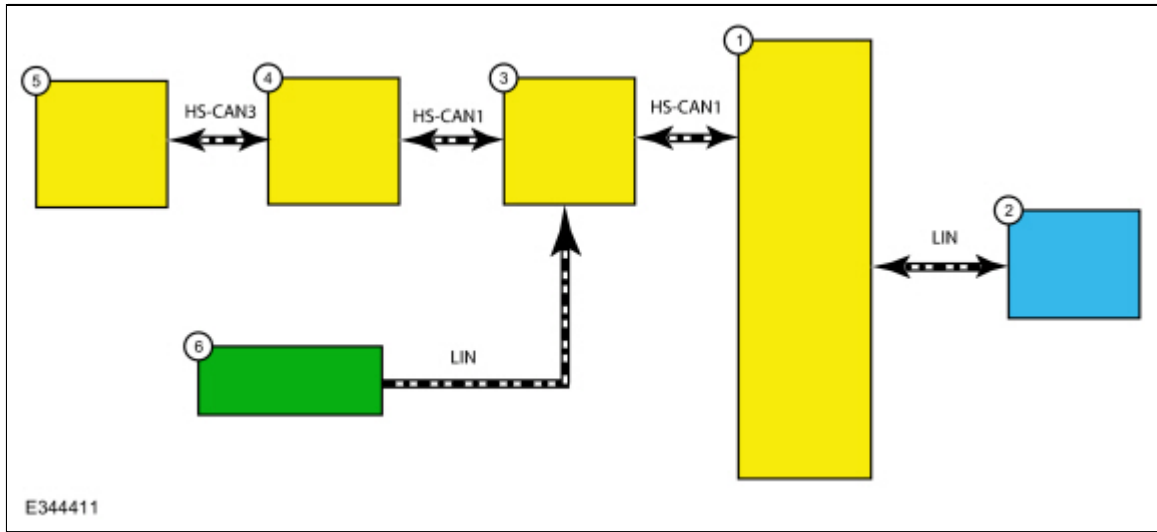

Item	Description
1	<u>PCM</u>
2	Generator
3	<u>GWM.g</u>
4	<u>BCM</u>
5	<u>IPC</u>
6	<u>BMS</u>

**Network Message Chart**

**Module Network Input Messages — Body Control Module (BCM)**

Broadcast Message	Originating Module	Message Purpose
Alternator fault (PwSrcULoFalt_D_Stat)	<u>PCM</u>	The <u>PCM</u> has detected a fault in the generator or generator circuits.

**Module Network Input Messages — Instrument Panel Cluster (IPC)**

--	--	--

Broadcast Message	Originating Module	Message Purpose
Power System Status (PwSysULoFalt_D_Stat)	<u>BCM</u>	Reports any generator/charging system faults. Used for charging system fault indicator.

### Module Network Input Messages — Powertrain Control Module (PCM)

Broadcast Message	Originating Module	Message Purpose
Load Shed Request (Shed_Level_Req)	<u>BCM</u>	Used to indicate what level of load shed is commanded.
Vehicle speed	<u>ABS</u> module	Vehicle speed is reported via. Used by the <u>PCM</u> during charging system voltage calculation.

### Charging System

The PCM controlled Smart Charge charging system determines the optimal voltage setpoint for the charging system and communicates this information to the voltage regulator. The Smart Charge charging system is designed to set a DTC when a charging system fault is present. All of the DTC can set continuous faults, but not all DTC 's set as on-demand faults.

The smart regenerative charge system primary strategy is stored in the BCM. The BCM receives information relating to the battery condition from the battery monitoring sensor via a LIN. The BCM calculates and sends the set value needed for the generator charging voltage via the HS-CAN to the PCM. The PCM then adjusts the value received (if necessary) and sends it to the generator via a different LIN. The charging voltage is adjusted depending on various parameters, such as the current level of engine efficiency. The smallest possible set value for the generator voltage is 12.2 volts, while the maximum charging voltage can be anywhere between 14.5 and 14.9 volts. However, when the battery is in a refresh phase, the voltage may occasionally reach up to 15.2 volts. These refresh phases are required when the battery charge status is 80% over long periods of time, which increases the risk of sulfation in the battery cells.

The PCM simultaneously controls and monitors generator output. When the current consumption is high or the battery is discharged, the PCM raises engine speed as needed to increase generator output. The generator charges the battery and at the same time supplies power for all electrical loads. The battery is more effectively charged with a higher voltage when the battery is cold and a lower voltage when the battery is warm.

The PCM turns off the generator during cranking to reduce the generator load and improve cranking speed. Once the engine starts, the PCM slowly increases generator output to the desired voltage.

The PCM reports any charging system faults and sends a message through the HS-CAN to the BCM. The BCM then sends a message over the MS-CAN to the IPC, which controls the charging system warning indicator. If equipped with a charging system warning indicator, the IPC turns the indicator on or off. If equipped with a message center, the IPC displays the corresponding message to notify the driver of the condition.

Under certain circumstances, the charging system may have a concern but still keeps the battery charged while the vehicle is running. The LIN is normally used to initiate charging, but with a fault in this circuit the

generator self-excites or begins charging on its own. The charging system warning indicator is illuminated and/or the corresponding message to notify the driver of the condition is displayed and the generator operates in a default mode (approximately 13.8 volts).

## Electrical Energy Management System

**NOTICE: When any vehicle module is being programmed, connect an external battery charger to make sure the module programming is completed without interruption due to the load shedding feature becoming active. The external battery charger must maintain a system voltage above 13 volts. This may require a charger setting higher than the lowest charge setting. The external battery charger negative connection must be made to an engine or vehicle chassis ground and not the negative battery terminal. If the connection is to the negative battery terminal, load shedding may begin and module programming may be corrupted. After charging has begun, start the engine to clear any load shed states and then turn the engine off and proceed with programming.**

This vehicle is equipped with an Electrical Energy Management system which manages battery charging and monitors the battery state of charge. The Electrical Energy Management system also utilizes a load shed strategy to help control discharge of the battery and prevent, when possible, an excessively low battery state of charge. The BCM uses a battery monitoring sensor to monitor the battery state of charge.

To maintain correct operation of the load shed system, any electrical devices or equipment must be grounded to the chassis ground and not the negative battery terminal. A connection to the negative battery terminal causes an inaccurate measurement of the battery state of charge and incorrect load shed system operation due to the current being used bypassing the battery monitoring sensor. Refer to the Battery Monitoring Sensor component description in this section.

## Battery State of Charge

The Battery monitoring system monitors the battery current flow and voltage to determine the battery state of charge. During the drive cycle the the battery monitoring system software monitors the charge and discharge current and increases the charge during charging, and decreasing it during discharge. During rest periods (key off with no electrical loads) when the vehicle enters sleep mode, the battery voltage is sampled to calibrate the state of charge. The sensor automatically executes this calibration anytime the vehicle enters sleep mode and when the total vehicle current draw is below 400mA. It takes 8 to 10 hours in the sleep mode to calibrate the battery state of charge to high accuracy. If the system draw does not allow the battery state of charge calibration over the previous 7 to 10 days the state of charge quality factor changes to flag this and some the battery monitoring system functions, which rely on the accuracy of the battery state of charge, may be temporarily turned off until a calibration takes place.

## Engine Off Load Shed

When the ignition is in **ACC** or **ON** mode and the BCM determines the battery voltage or the battery state of charge has dropped below set levels, a low battery warning message is displayed in the message center. Should the battery voltage or the battery state of charge continue to drop, the audio system is powered down to save the remaining battery charge. This load shed state clears once the vehicle is started and battery state of charge is allowed to recover.

When the ignition is in the ON mode and load shed occurs, the message center displays the corresponding message to notify the driver that battery protection actions are active. The audio system shuts down after the message center displays the warning.

If a fault occurs with the battery monitoring sensor or circuit(s), the only engine off load shed strategy that is active is a 45 minute timer. After 45 minutes have elapsed, the audio system turns off. To clear the load shed state, restart the engine.

## Engine Running Load Shed

When the BCM and/or PSCM voltage is low, with the engine running, a message is sent by the BCM to either minimize or shut down the climate controlled seats, rear defrost, heated mirrors and DATC blower motor to improve system voltage. Under this condition, the IPC message center displays either LOW BATTERY LESS FEATURES (base message center) or Electrical Power Saver Active. Some Features Turned Off See Manual to notify the driver that battery protection actions are active.

For more information on message center messages, Refer to the Owner's Literature or **Refer to: Warning Chimes (413-01 Instrumentation, Message Center and Warning Chimes, Description and Operation).**

**There are 3 states of engine running load shed:**

Load Shed State	Entry Conditions	Impact to Features	Clear Conditions
Load shed 1	If power source (alternator/DCDC) is fully saturated in combination with low battery voltage and low battery SOC.	These loads are incrementally reduced (if equipped): Heated steering wheel and climate controlled seats. These loads are turned off (if equipped): smart trailer tow battery charge, heated mirrors, any climate features.	Power source no longer saturated and battery voltage has recovered.
Load shed 2 transient	<u>PSCM</u> indicating reduced voltage and increased current. System voltage less than 11 volts.	<ul style="list-style-type: none"> <li>• If equipped, climate controlled seats are disabled, but the indicators remain illuminated.</li> <li>• If equipped, rear defrost and heated mirrors are disabled, but the indicator remain illuminated.</li> </ul>	Voltage to the <u>BCM</u> is greater than 12.5 volts.
Load shed 2 continuous	Load Shed 2 Transient condition present for up to 60sec.	<ul style="list-style-type: none"> <li>• If equipped, any climate features are disabled and indicators are off.</li> <li>• If equipped with <u>DATC</u>, the blower motor is reduced to 50% speed.</li> <li>• If equipped, DC/AC inverter (AC powerpoint) is disabled.</li> <li>• The <u>IPC</u> message center displays "Electrical Power Saver Active. Some Features Turned Off See Manual.</li> </ul>	Voltage to the <u>BCM</u> is greater than 12.4 volts for more than 60 seconds.

### Battery Charging

**NOTICE: If the charger is incorrectly connected to the battery negative terminal, DO NOT reset the battery monitoring system using the diagnostic scan tool. This reset is reserved for new battery installation only. This reset will clear the learned battery data, the battery time in service, and will affect the aging algorithm parameters, which have been learned since the installation of the battery.**

**NOTICE: The battery monitoring system will recalibrate itself after 6 hours ignition off.**

When it is required to charge the vehicle battery, connect the positive connection to the battery positive post, and place the charger negative cable to vehicle ground. Do not connect the negative charger cable to the battery negative terminal. Connecting directly to the battery negative terminal bypasses the vehicle sensors, not allowing the BMS to detect the charge current. As a result the battery state of charge does not reflect the charging. Look for the body ground cable coming off the clamp or the battery monitoring sensor and try and connect in this location (typically on the shock tower sheet metal).

If the battery is being charged due to a load shedding message, only properly charging the battery assists in clearing this message. If the charger was properly installed, the BMS system calibrates the battery state of charge after about 8 hours.

Refer to: [Battery Charging](#) (414-01 Battery, Mounting and Cables, General Procedures).

## Jump Starting

When it is required to jump start the vehicle, just like battery charging, it is important to connect the cables properly for the Electrical Energy Management system to measure the energy input to the system to keep an accurate state of charge. Connect the positive connection to the battery positive post, and connect the negative cable to a vehicle ground. Do not connect to the negative battery terminal. Connecting directly to the battery negative terminal bypasses the ability of the vehicle to measure the input current with the battery monitoring sensor, and does not adjust the battery state of charge accordingly. For a convenient ground location look for the body ground cable coming off the clamp or the battery monitoring sensor and try and connect in this location (typically on the shock tower sheet metal). The battery monitoring system calibrates the battery state of charge as described above after about 8 hours if the jump start negative cable is improperly installed.

**NOTICE: If the cables are incorrectly connected to the battery negative terminal, DO NOT reset the battery monitoring system using the diagnostic scan tool. This reset is reserved for new battery installation only. This reset will clear the learned battery data, the battery time in service, and will affect the aging algorithm parameters, which have been learned since the installation of the battery.**

## Battery Replacement

If the vehicle battery is replaced, it is very important to perform the battery monitoring system reset using the diagnostic scan tool. If the battery monitoring system reset is not carried out, it holds the old battery parameters and time in service counter in memory. Additionally it tells the system the battery is in an aged state and may limit the Electrical Energy Management system functions.

Refer to: [Battery](#) (414-01 Battery, Mounting and Cables, Removal and Installation).

## Component Description

### Generator

The generator is equipped with an electronic internal voltage regulator and a serviceable generator clutch pulley.

Refer to: [Generator Pulley](#) (414-02 Generator and Regulator, Removal and Installation).

### Battery Monitoring Sensor

**NOTICE: Unless the battery is being replaced, DO NOT reset the battery monitoring system using the diagnostic scan tool. This reset is reserved for new battery installation only. This reset will clear the learned battery data, the battery time in service, and will affect the aging algorithm parameters, which have been learned since the installation of the battery.**

The battery monitoring sensor is integrated with the negative battery terminal clamp and cable assembly, which provides a ground to the sensor. The battery monitoring sensor measures voltage, current, and temperature of the battery and uses these inputs to calculate the battery condition. The sensor transmits this information through the LIN circuit to the BCM. The battery monitoring sensor has a 2-pin connector providing battery voltage and LIN connections.

The battery monitoring sensor is an input to the Electrical Energy Management system software. If the sensor malfunctions due to wiring issues or failure, a DTC sets. In most cases the Electrical Energy Management system functions are turned off until the sensor operation is restored.

## Powertrain Control Module (PCM)

The PCM monitors and controls the charging system.

## Generator Clutch

The generator clutch is eventually serviced separately from the generator - check Refer to: [Generator Pulley](#) (414-02 Generator and Regulator, Removal and Installation). The primary function is to separate the generator rotor inertia from the FEAD belt, lowering belt tension at high Revolutions Per Minute (RPM) and reducing NVH.

Copyright © Ford Motor Company

---