

## A-Pillar Trim Panel - 3-Door

## Special Tool(s) / General Equipment

Interior Trim Remover

## Removal

**⚠ WARNING:** The following procedure prescribes critical repair steps required for correct restraint system operation during a crash. Follow all notes and steps carefully. Failure to follow step instructions may result in incorrect operation of the restraint system and increases the risk of serious personal injury or death in a crash.

**NOTE:** Removal steps in this procedure may contain installation details.

**NOTE:** Left hand (LH) shown, right hand (RH) similar.

- ⚠ WARNING:** Before beginning any service procedure in this manual, refer to health and safety warnings in section 100-00 General Information. Failure to follow this instruction may result in serious personal injury.

Refer to: [Pyrotechnic Device Health and Safety Precautions](#) (100-00 General Information, Description and Operation).

- Depower the SRS .  
Refer to: [Supplemental Restraint System \(SRS\) Depowering](#) (501-20B Supplemental Restraint System, General Procedures).
- Release the clips and remove the hard top flip latch bolt cover.

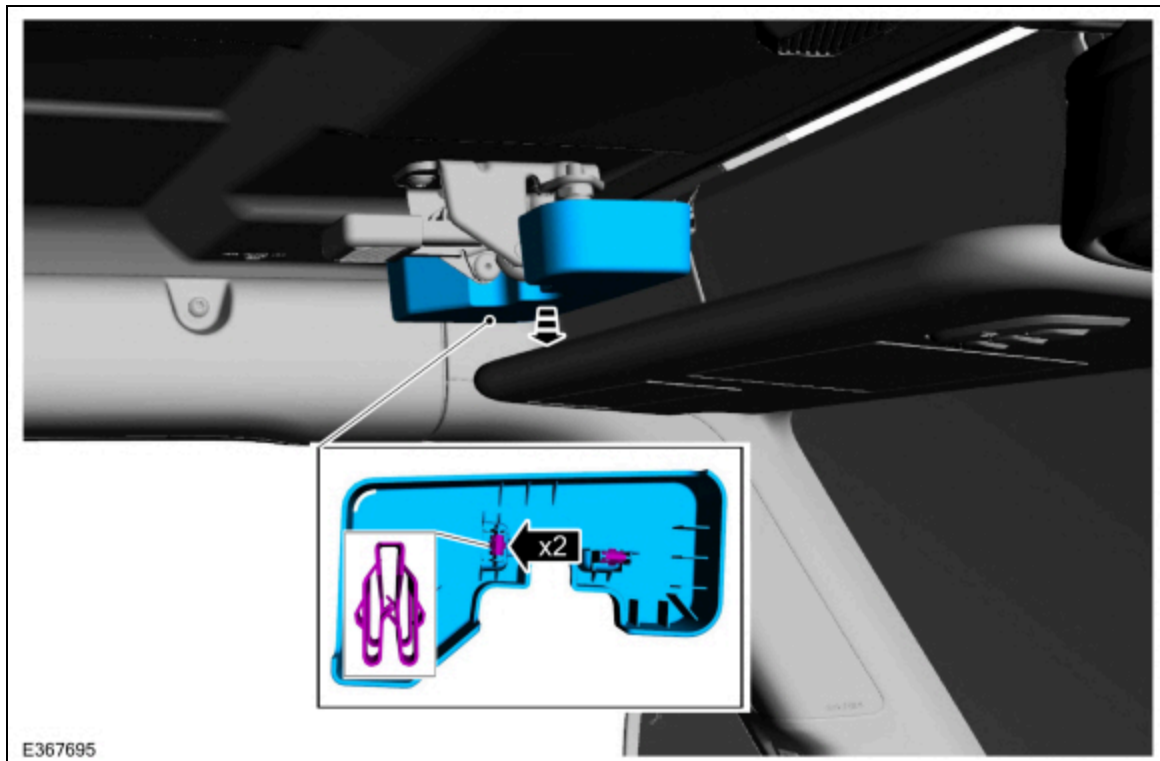

- Remove the screws and the upper rail front trim panel.  
*Torque:* 28 lb.in (3.2 Nm)

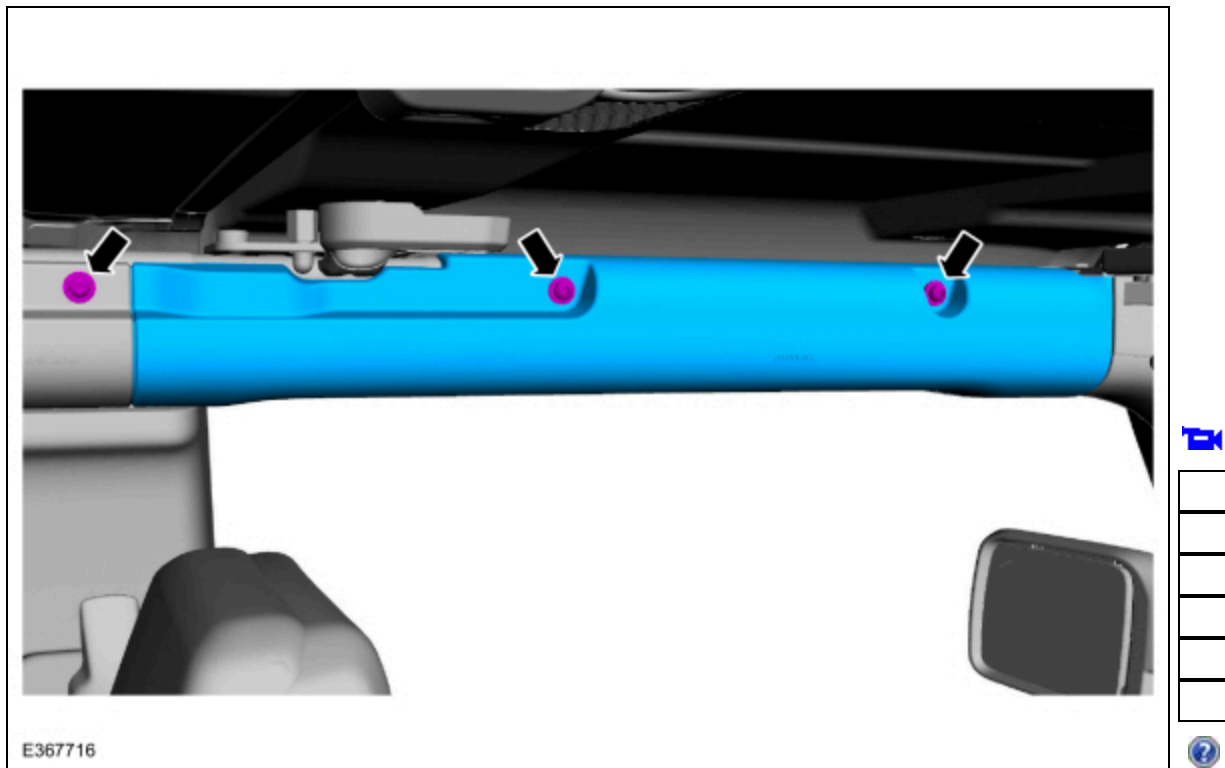

5. Release the tabs and the clip and position the A-pillar trim panel cover aside.  
Use the General Equipment: Interior Trim Remover

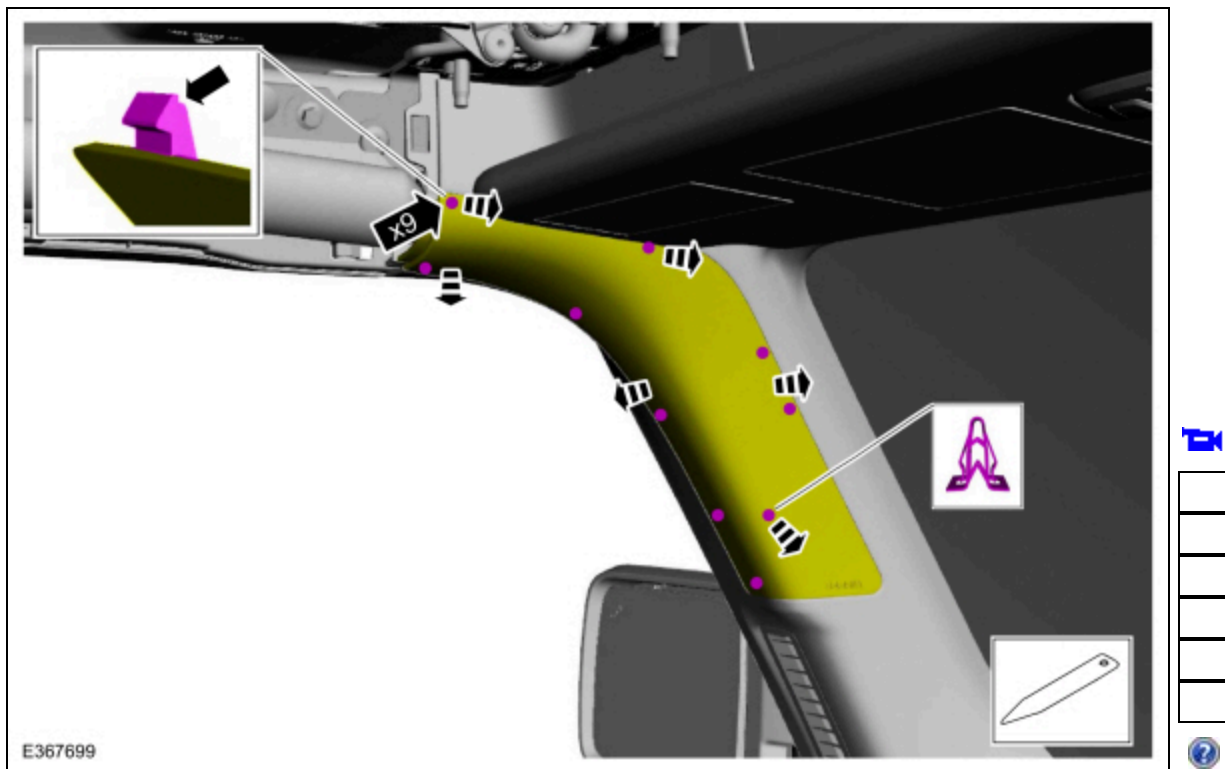

6. Remove the A-pillar trim panel cover.
  1. Remove the A-pillar trim panel cover tether clip screw.  
*Torque: 28 lb.in (3.2 Nm)*
  2. Release the A-pillar trim panel cover tether clip from the A-pillar trim panel cover.

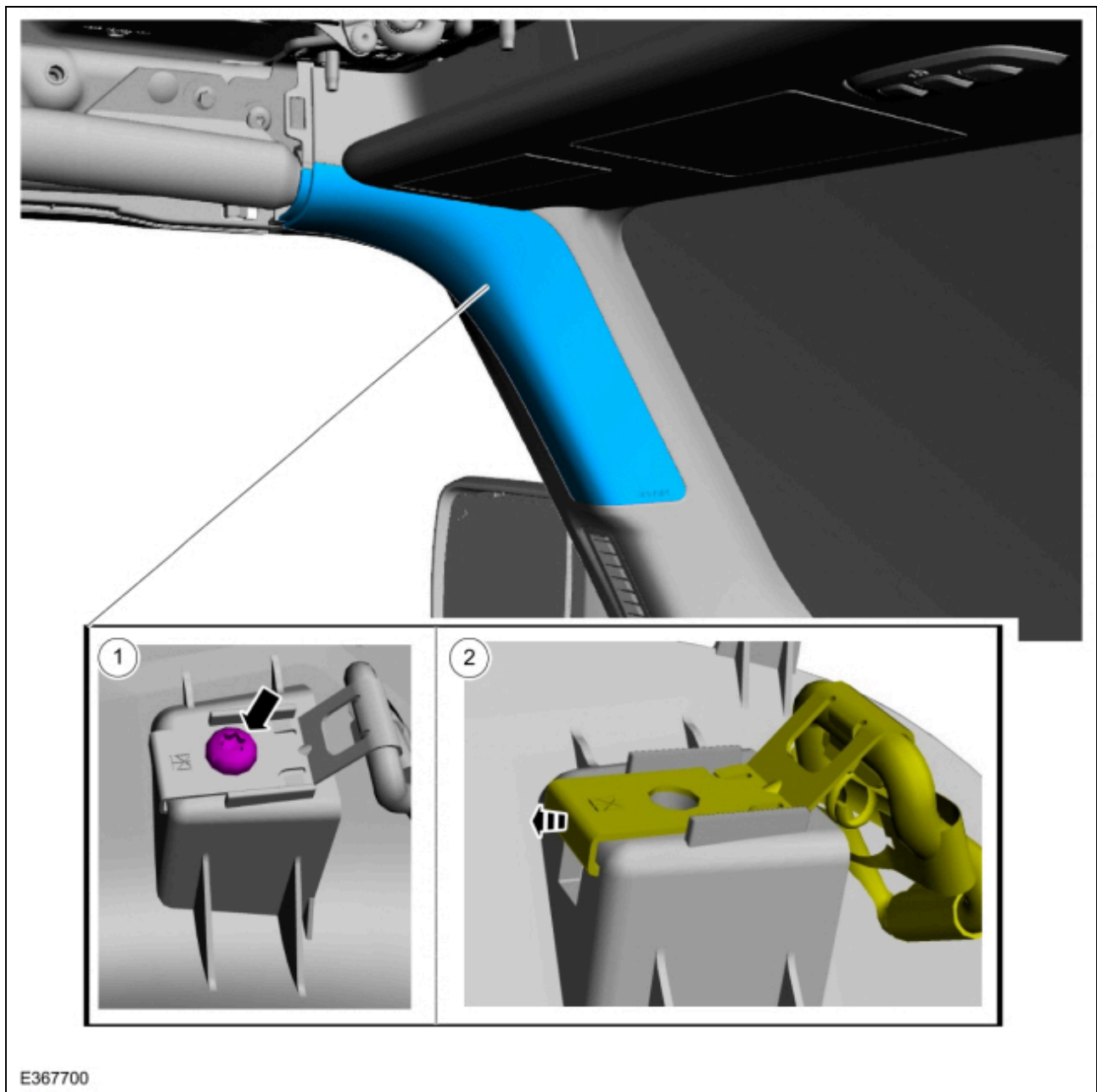

E367700

7.

Position the side curtain airbag aside.

1. Remove the bolt.

*Torque:* 80 lb.in (9 Nm)

2. Remove the bolt.

*Torque:* 80 lb.in (9 Nm)

3. Lift upward and outward on the side curtain airbag tether clip and position aside.

4. Release the side curtain airbag pin-type retainer.

Use the General Equipment: Interior Trim Remover

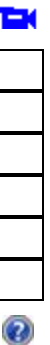

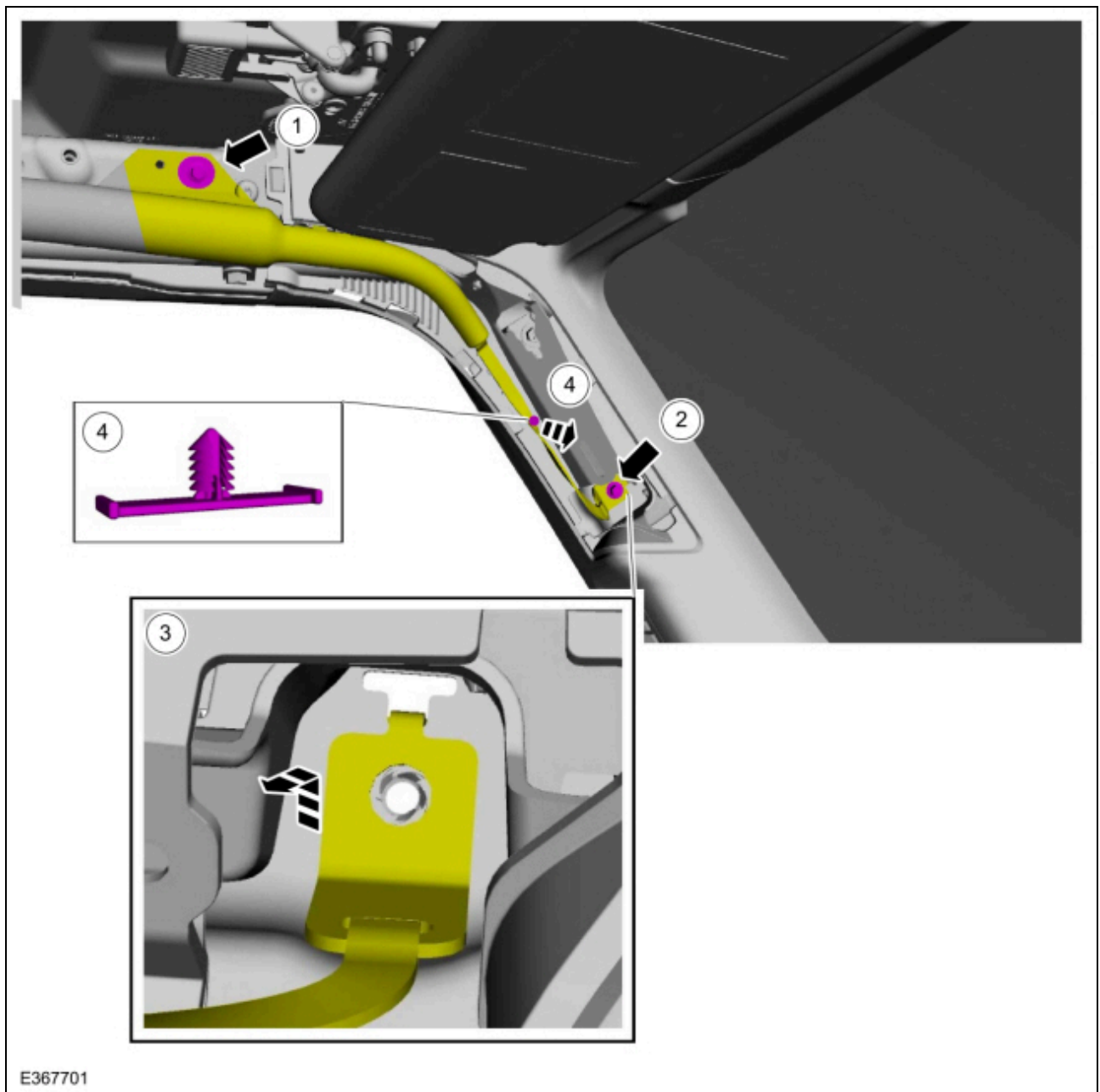

E367701

8. Remove the sun visor.
  1. Position the sun visor screw cover aside.
  2. Remove the sun visor screw.
  3. Release the sun visor from the roof.
  4. If equipped.
    - Disconnect the sun visor electrical connector.

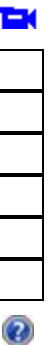

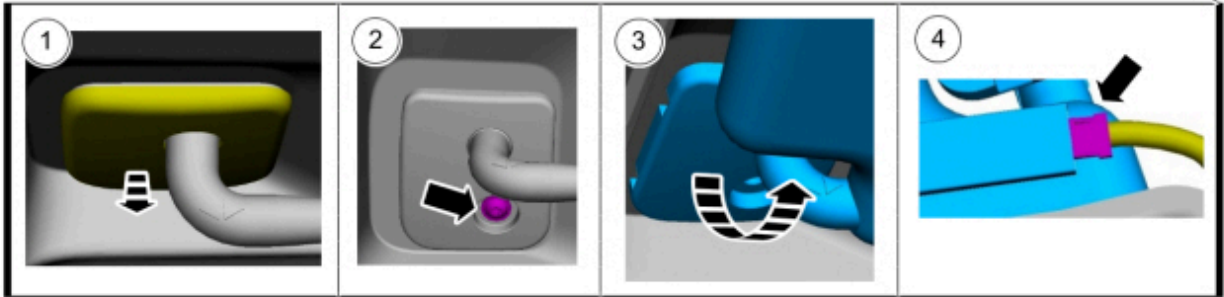
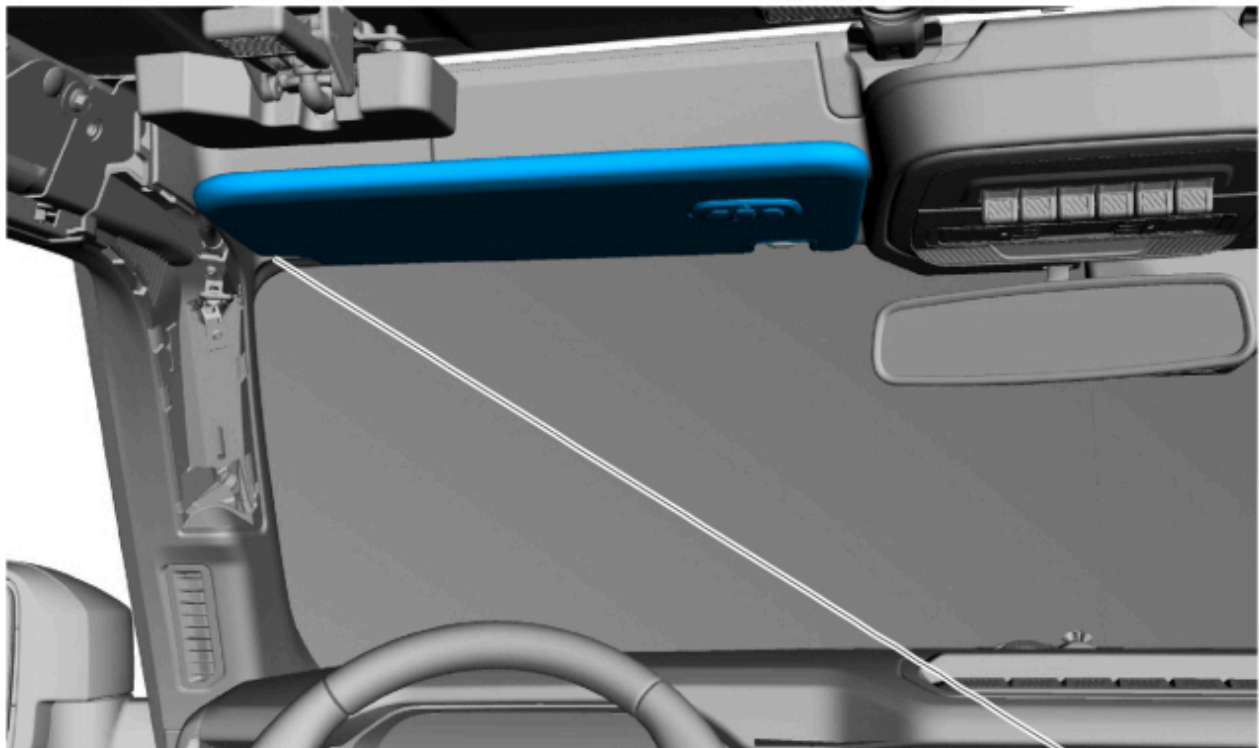

E351865

9. Remove the screws and the instrument panel grab handle.  
*Torque: 42 lb.in (4.8 Nm)*





10. Release the clips and remove the cowl side trim panel.  
Use the General Equipment: Interior Trim Remover

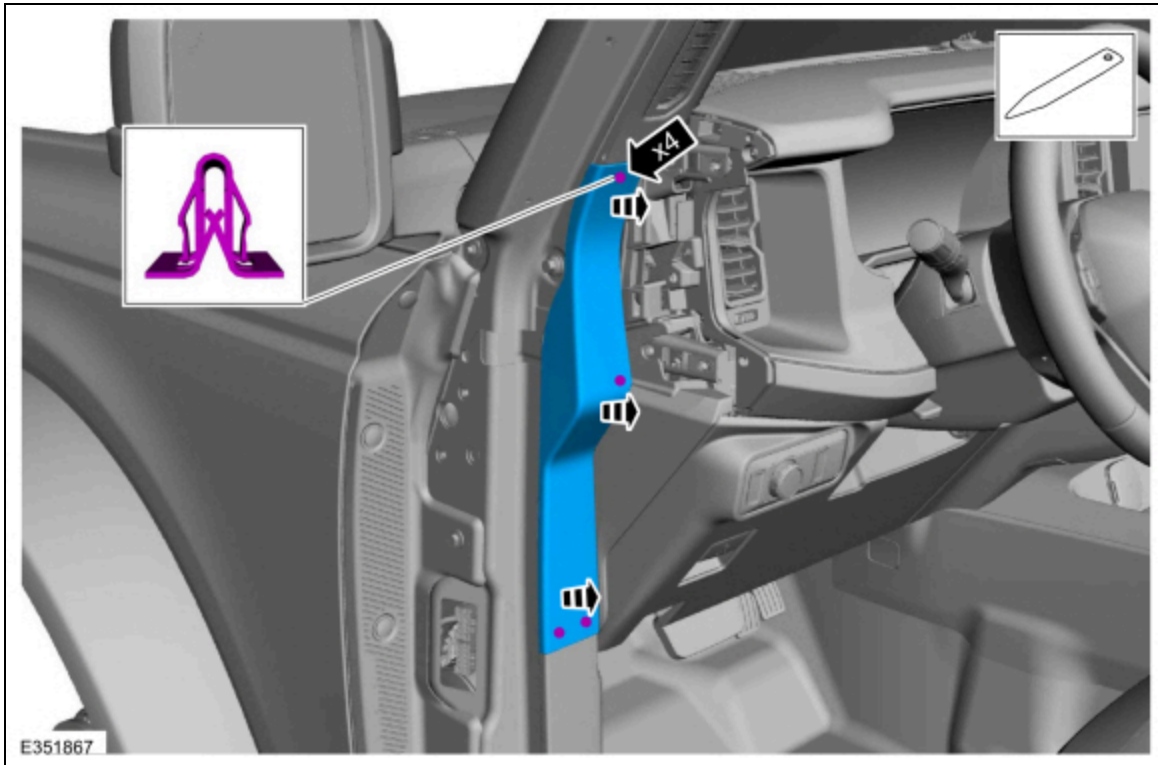

11. Remove the A-pillar trim panel.
1. Release the clips and the upper tab.  
Use the General Equipment: Interior Trim Remover
  2. Lift upward and outward on the A-pillar trim panel and disconnect the lower tabs.

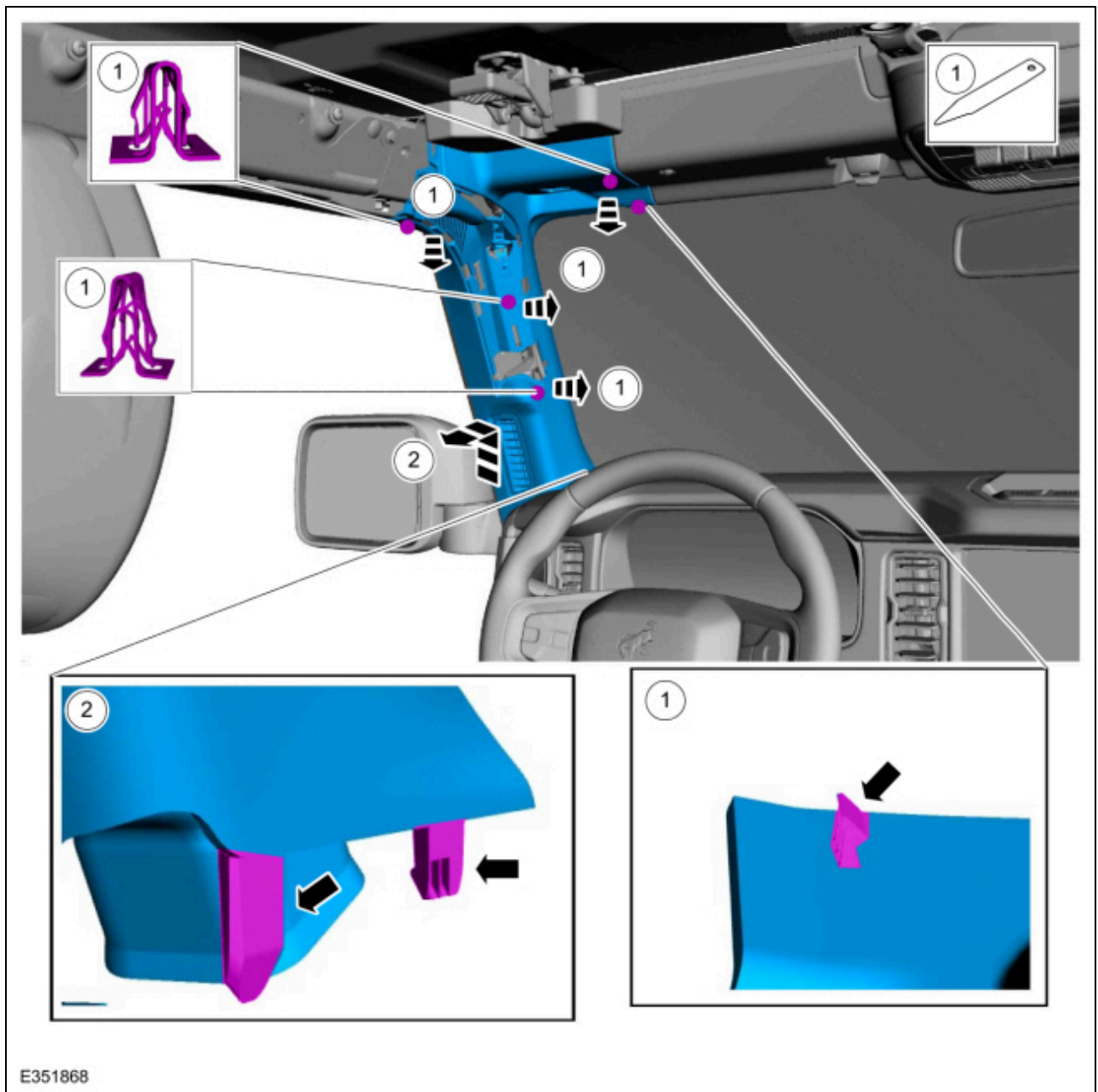

E351868

## Installation

1. To install, reverse the removal procedure.
2. Repower the SRS .  
Refer to: [Supplemental Restraint System \(SRS\) Repowering](#) (501-20B Supplemental Restraint System, General Procedures).

